

SMD Power Inductor NR - 3010-Series (Ferrite)



2020/1/1

Features & Application

- Mounting on the surface of NR inductors has high power current sensing.
 - NR inductors are small in size and are miniaturized products, but the chip inductors have high quality, huge storage capacity and low resistance characteristics
 - Surface mount high power inductors.
 - Reel packaging is available for automatic surface mounting.
 - It has the characteristics of high Q value and low impedance
- Low magnetic leakage, low direct resistance, high current resistance and a series of features.
- It is widely used in notebook computers, desktop computers, servers, plug-ins, TVs, smart homes, LED lighting, automotive products, wireless remote control systems, low-voltage power supply modules and other electronic equipment.

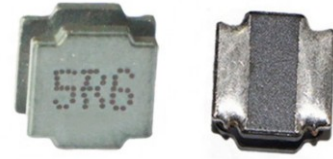

★ When ordering, please check part number

Part Number	Inductance @1MHz,0.25V (uH)	DCR (Max) (Ω)	Isat (Max.) (A)	Irms (Max.) (A)	SRF MHz (min)
FNR3010-1R0N1.4A	1.0±30%	0.065	1.4	1.45	180
FNR3010-1R5N1.27A	1.5±30%	0.08	1.27	1.3	120
FNR3010-2R2N1.15A	2.2±30%	0.11	1.15	1.09	100
FNR3010-3R3N0.97A	3.3±30%	0.145	0.97	0.96	74
FNR3010-4R7M0.75A	4.7±20%	0.225	0.75	0.77	59
FNR3010-6R8M0.55A	6.8±20%	0.305	0.55	0.66	42
FNR3010-100M0.55A	10±20%	0.4	0.55	0.58	39
FNR3010-150M0.42A	15±20%	0.61	0.42	0.47	30
FNR3010-220M0.35A	22±20%	0.93	0.35	0.38	28
FNR3010-330M0.29A	33±20%	1.55	0.29	0.3	18

1. Isat: DC current at which the inductance drops approximate 30% from its value without current;
2. Irms: DC current that causes the temperature rise ($\Delta T = 40^{\circ}\text{C}$) from 25°C ambient;
3. Operating Temperature : $-40^{\circ}\text{C} \sim +125^{\circ}\text{C}$;
4. Absolute maximum voltage: DC 25V

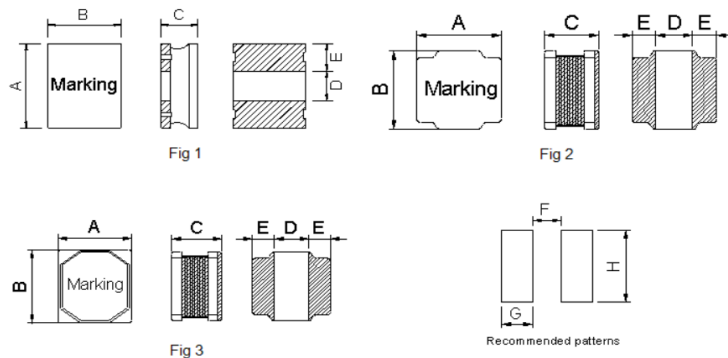

Dimensions	
A	3.00±0.20
B	3.00±0.20
C	1.10 max
D	1.20±0.3
E	0.90±0.3
F	1.10 typ
G	1.00 typ
H	2.70 typ
Fig 3	
unit : mm	

Impedance/Inductance/Q/	LCR Angilent E4991A
Resistance DC	Chroma 16502
Current per winding that causes a 20°C rise from 25°C ambient	
Electrical specifications at 25°C	

Weight 43 – 47 mg.

Packaging 2000/7 " reel; Plastic tape: 8 mm wide.

Packaging will different, according the various chip size.

Contact Us	
US	sales-us@bing-ri.com.tw
Taiwan	sales-tw@bing-ri.com.tw
China	sales-cn@bing-ri.com.tw
Japan	sales-jp@bing-ri.com.tw

Official Website :
https://www.bing-ri.com.tw/

GENERAL CHARACTERISTICS

1. Operating temperature range: -40 TO + 125°C (Includes temperature when the coil is heated)
2. External appearance: On visual inspection, the coil has no external defects.
3. Terminal strength: After soldering. Between copper plate and terminals of coil. Push in two directions of X.Y withstanding at below conditions.
Terminal should not peel off. (refer to figure at right) 0.5kg Min –3010
4. Insulating resistance: Over 100MΩ at 100V D.C. between coil and core.
5. Dielectric strength: No dielectric breakdown at 100V D.C. for 1 minute between coil and core
6. Temperature characteristics: Inductance coefficient (0~2,000)x10⁻⁶/ (°C -25~+80). °C , inductance deviation within±5.0%, after 96 hours.
7. Humidity characteristics(Moisture Resistance): Inductance deviation within ±5%, after 96 hours in 90~95% relative humidity at 40 ±2 and 1 hour drying under normal condition.
8. Vibration resistance: Inductance deviation within ±5%, after vibration for 1 hour. In each of three orientations at sweep vibration (10~55~10 Hz) with 1.5mm P-P amplitudes.
9. Shock resistance: Inductance deviation within ±5%, after being dropped once with 981m/s² (100G) shock attitude upon a rubber block method shock testing machine, in three different
10. Resistance to Soldering Heat: 260 , 10 seconds(See attached recommend reflow)
11. Storage environment: Storage condition: Temperature Range: 10 ~ 35 (Generally: 21 ~ 31) , Humidity Range: 50% ~ 80% RH (Generally: 65% ~ 75%) ; Transportation condition: Temperature Range:-35 ~ 85 , Humidity Range: 50% ~ 95% RH
12. Use components within 12 months. If 12 months or more have elapsed, check solderability before use.
13. Reflow profile recommend:

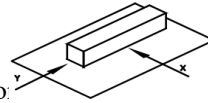

Lead-free heat en duran ce test

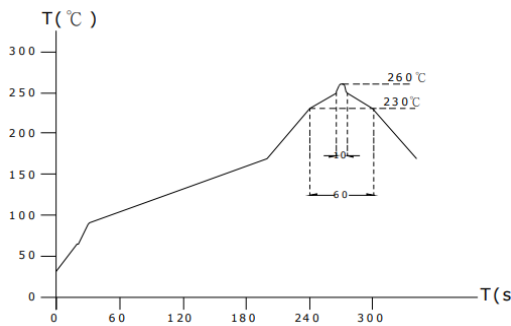

Lead-free the recommended reflow condition

